



## Danfoss Heat Pump DHP-A

Air/water heat pump that provides heating and hot water.

Danfoss DHP-A is an air/water heat pump that uses new innovative technology to operate at the highest possible annual efficiency. This means you can get 75% of your energy consumption for free – using renewable energy stored in the outdoor air. This provides a sustainable and environmentally friendly heating solution.

The integrated hot water tank incorporates our patented TWS\* technology, producing hot water faster and at higher temperatures than with traditional technology.

Defrosting is done automatically only on demand which further boosts efficiency.

DHP-A operates at a low sound level and can be controlled and monitored via the Internet. The controller is advanced but very user friendly.

\* Tap Water Stratificator, our patented technology developed to stratify hot water in a tank to ensure that heat is used optimally.

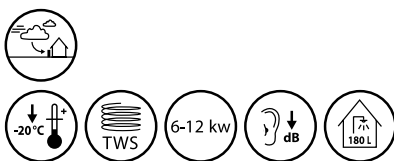

# DANFOSS DHP-A

## Connection

- 1 Brine in, 28 Cu
- 2 Brine out, 28 Cu

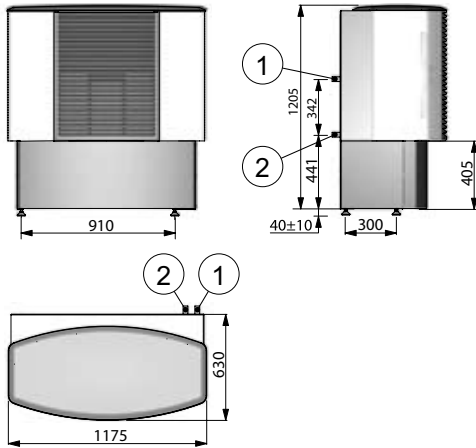

## Connection

The brine pipes can be connected on either the left or right-hand sides of the heat pump.

- 1 Brine in, 28 Cu
- 2 Brine out, 28 Cu
- 3 Lead-in for incoming power supply, sensors and communication cable
- 4 Heating system supply line, 22 Cu: 6-10 kW, 28 Cu: 12 kW
- 5 Heating system return line, 22 Cu: 6-10 kW, 28 Cu: 12 kW
- 6 Expansion pipe, 22 Cu
- 7 Hot water pipe, 22 Brass
- 8 Cold water pipe, 22 Brass
- 9 Expansion outlet brine circuit, DN25 int.
- 10 Temperature and pressure valve

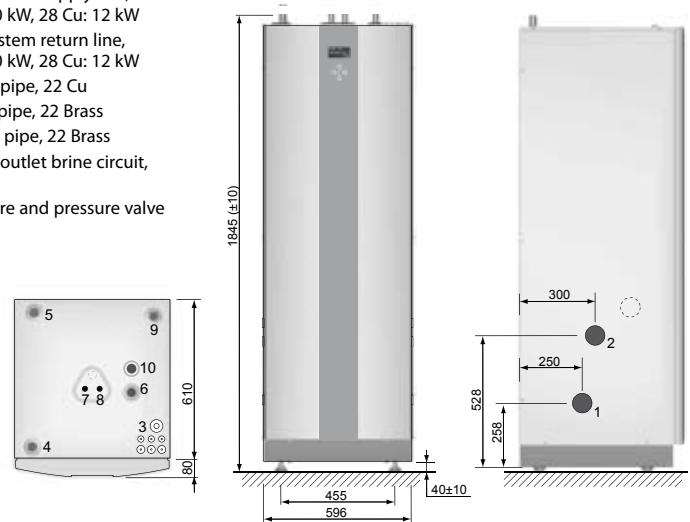

DHP-A			6	8	10	12
<b>Refrigerant</b>	Type		R404A	R404A	R404A	R404A
	Amount	kg	0.95	1.45	1.50	1.60
<b>Compressor</b>	Type		Scroll	Scroll	Scroll	Scroll
<b>Electrical data</b> 3-N ~50Hz	Main supply	Volt	400	400	400	400
	Rated power compressor	kW	2.0	2.3	3.6	4.4
	Rated power, circulation-pumps/fan	W	0.4	0.6	0.6	0.6
	Auxiliary heater, 5 steps	kW	3/6/9/12/15	3/6/9/12/15	3/6/9/12/15	3/6/9/12/15
	Start current	A	14	25	29	32
	Circuit breaker	A	10 <sup>3</sup> /16 <sup>3</sup> /20 <sup>3</sup> /20 <sup>3</sup> /25 <sup>3</sup> /25 <sup>3</sup> /30 <sup>3</sup>	16 <sup>3</sup> /16 <sup>3</sup> /20 <sup>3</sup> /20 <sup>3</sup> /25 <sup>3</sup> /25 <sup>3</sup> /30 <sup>3</sup>	16 <sup>3</sup> /16 <sup>3</sup> /20 <sup>3</sup> /20 <sup>3</sup> /25 <sup>3</sup> /30 <sup>3</sup> /35 <sup>3</sup>	16 <sup>3</sup> /20 <sup>3</sup> /25 <sup>3</sup> /25 <sup>3</sup> /30 <sup>3</sup> /35 <sup>3</sup>
<b>Electrical data</b> 1-N ~50Hz	Main supply	Volt	230	230	230	230
	Rated power compressor	kW	3.3	4.2	5.4	5.7
	Rated power, circulation-pumps/fan	W	0.4	0.6	0.6	0.6
	Auxiliary heater, 3 steps	kW	1.5/3/4.5	1.5/3/4.5	1.5/3/4.5	1.5/3/4.5
	Start current	A	58	76	97	108
	Circuit breaker	A	25 <sup>3</sup> /32 <sup>3</sup> /40 <sup>3</sup>	25 <sup>3</sup> /32 <sup>3</sup> /40 <sup>3</sup>	32 <sup>3</sup> /40 <sup>3</sup> /50 <sup>3</sup>	32 <sup>3</sup> /40 <sup>3</sup> /50 <sup>3</sup>
<b>Performance</b>	COP <sup>1</sup>		3.88	4.06	4.21	4.06
	COP <sup>2</sup>		3.26	3.45	3.29	3.35
	Heating capacity <sup>2</sup>	kW	5.90	7.96	9.85	11.3
	Power input <sup>2</sup>	kW	1.8	2.3	3.0	3.4
<b>Lowest outdoor temperature allowed for compressor start</b>		°C	-20	-20	-20	-20
<b>Max/min temperature</b>	Cooling circuit	°C	20/-25	20/-25	20/-25	20/-25
	Heating circuit	°C	55/20	55/20	55/20	55/20
<b>Water volume</b>	Water heater	l	180	180	180	180
<b>Anti freeze media<sup>10</sup></b>	Ethylene glycol + Water solution with a freezing point below -30°C					
<b>Indoor unit</b>	Dimensions LxWxH	mm	690x596x1845	690x596x1845	690x596x1845	690x596x1845
	Weight empty	kg	260	260	260	268
	Weight filled	kg	440	440	440	448
	Sound power level <sup>11</sup>	dB(A)	42.5	47.7	45.5	48.1
<b>Outdoor unit</b>	Dimensions LxWxH	mm	630x1175x1245	630x1175x1245	630x1175x1245	630x1175x1245
	Weight	kg	94	94	94	94
	Sound power level, low/high <sup>12</sup>	dB(A)	53/63	53/63	54/67	54/67
<b>Max. pipe length (Cu pipe Ø 28 mm between heat pump and outdoor unit)</b>		m	210 (105+105)	131 (65+65)	70 (35+35)	76 (38+38)

The measurements are performed on a limited number of heat pumps which can cause variations in the results. Tolerances in the measuring methods can also cause variations.

- 1) At A7W35 Δ10 warm side (excluding circulation pumps and outdoor unit).
- 2) At A7W35 according to EN 14511 (including circulation pumps and outdoor unit).
- 3) Heat pump with 3 kW auxiliary heater (1-N 1.5 kW).
- 4) Heat pump with 6 kW auxiliary heater (1-N 3 kW).
- 5) Heat pump with 9 kW auxiliary heater (1-N 4.5 kW).
- 6) 12 kW auxiliary heater (compressor off).

- 7) 15 kW auxiliary heater (compressor off).
- 8) Heat pump with 12 kW auxiliary heater.
- 9) Heat pump with 15 kW auxiliary heater.
- 10) Propylene glycol or ethanol may not be used.
- 11) Sound power level measured according to EN ISO 3741 at A7W45 (EN 12102).
- 12) Sound power level measured according to EN ISO 3741.